

Datacard Group



Artista™

Custom Card Printer

Trends in the Card Market

- Artista was developed based on emerging trends.
- “Markets of one” - Customers prefer choice in their card designs.
- Smaller production runs are increasing.
- Faster time to market - cards into customers’ hands more quickly than the competition
- Need for lower cost per card - save money in production costs.
- Use of the Internet to order cards
- Gift cards is fastest growing market segment.



What Is the Artista™ Custom Card Printer?

- The Artista printer is a high speed **on demand** standalone digital card printer.
- Prints true edge-to-edge full card images at 300 dpi continuous tone ribbons
- Prints at 1,000 cph
- Cards can be sent downstream to Datacard 7000/9000 for additional personalization, topping, or delivery.

The Artista printer merges digital information:

- Card designs
- Logos
- Cardholder information
- Signatures
- Fixed and variable data
- Photographs

...and then prints cards edge-to-edge at high speed.

Cardholder Name
Cardholder Number

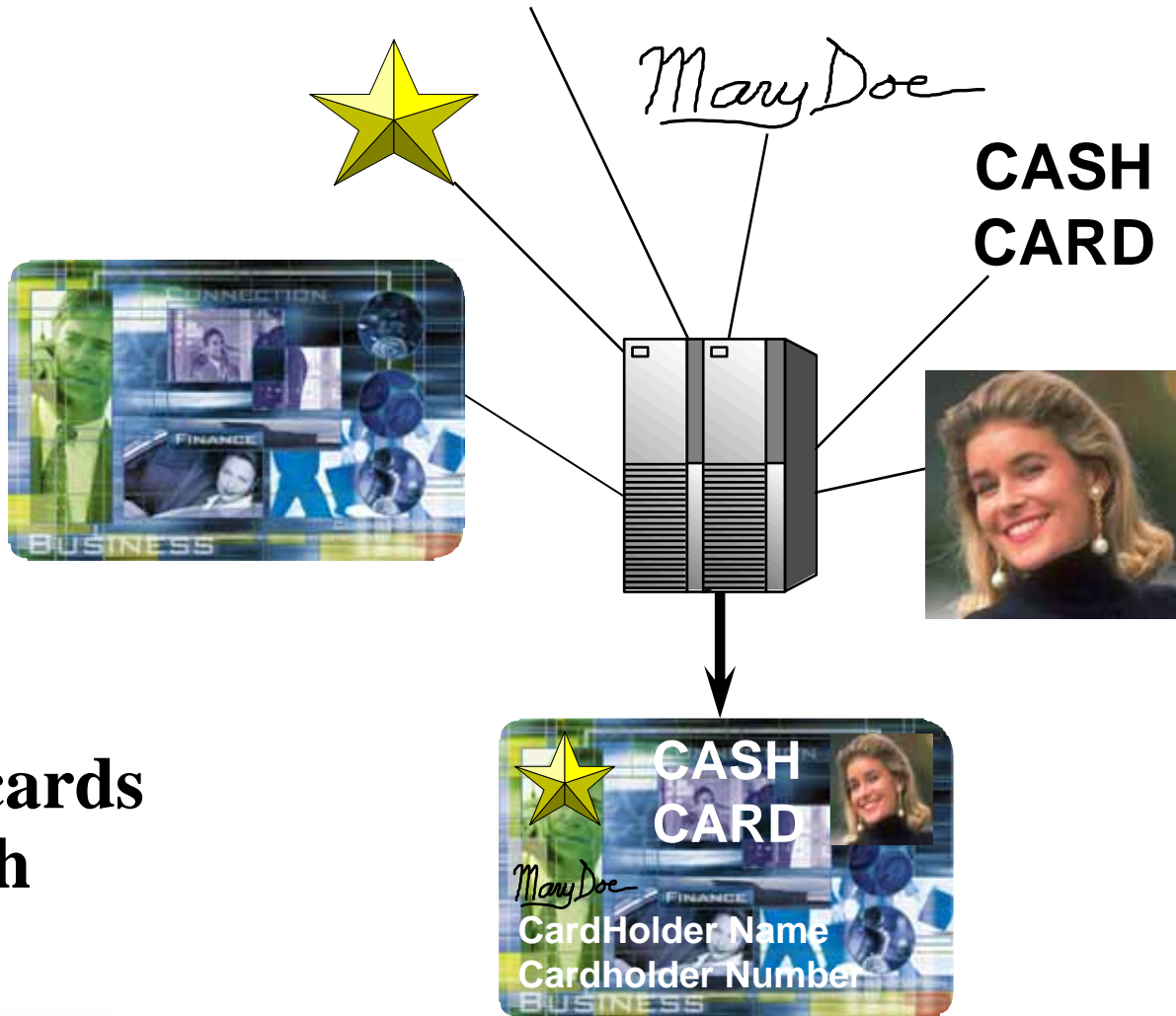

Datacard Group

The Artista printer prints custom images on generic stock.



1. Load white card stock.

2. The Artista printer prints the entire card.

3. Downstream 7000/9000 modules can emboss, top, deliver...

Every card can be unique.



Datacard Group

New card products can be introduced quickly!



Morning

Capture image or use original design.



Noon

Scan, touch-up, crop, save...



End of Day

Cards personalized, printed, and delivered !

Datacard Group

Artista Benefits to Marketing

- Respond to interest in “markets of one” or need for customization
- Provides easy and affordable mass customization
- Creates market differentiation - flexibility to implement creative marketing programs
- Provides faster time to market
- Allows benefits from “event marketing”
- Internet used as card marketing tool for customized cards



Artista Benefits to Card Operations

- Greatly improved turnaround time - respond to Marketing demands for implementation of new programs
- Fewer card types and reduced inventory and card obsolescence through use of white card stock
- Simplified job set up means small runs are economically feasible (compared to offset press & 9000)
- Error log and job tracking



Economics of the Artista Printer

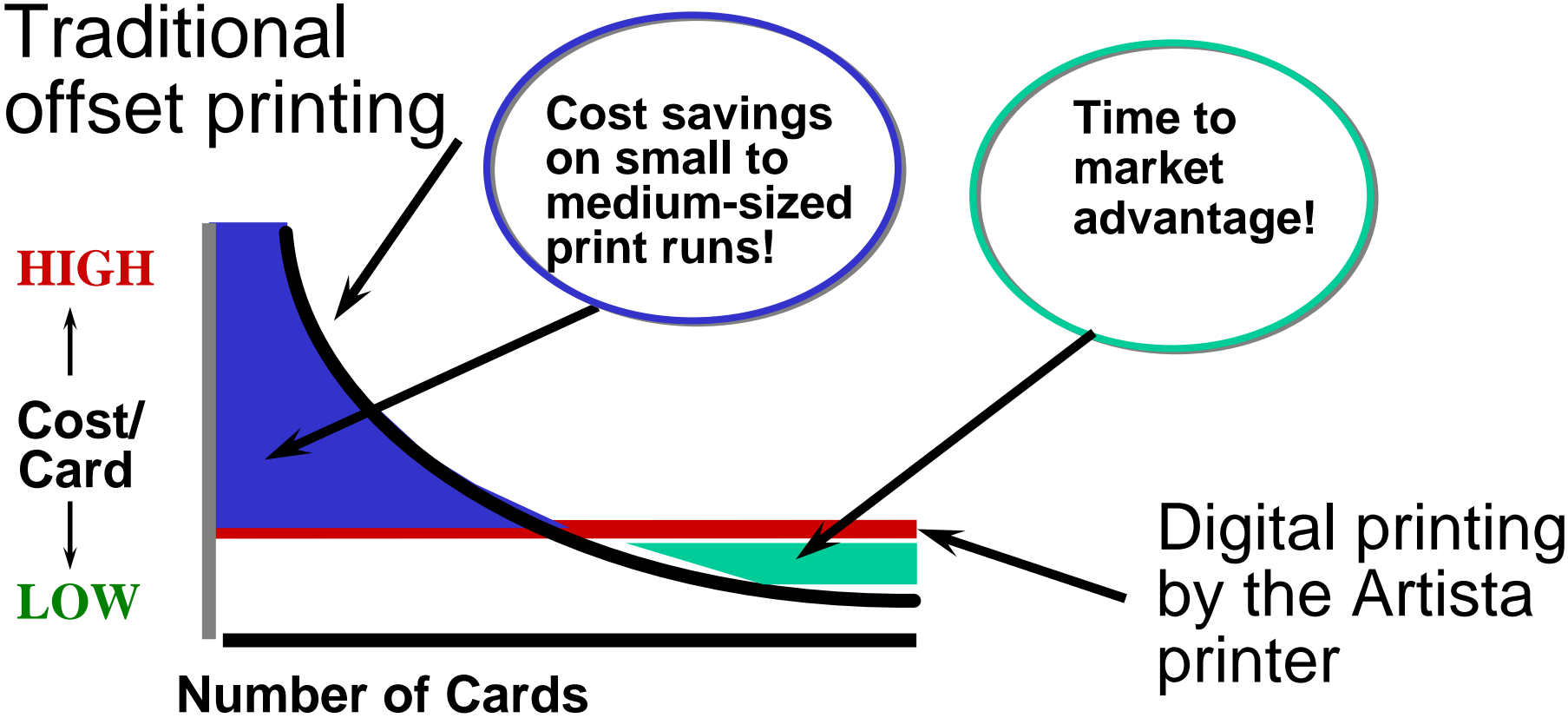

Why Personalized Designs?

- Customer Acquisition
 - 11% increase in new accounts per month
- Profitability per Account
 - Activation : increased 40% ~ 49%
 - Dollar Amount per Transaction : increased 30%
 - Outstanding Balance : increased 34%
 - Monthly Volume : increased 62%
- Customer Loyalty and Retention
 - U.S. average rate of customer attrition: 15~20%
 - Average rate of customer attrition for Picture Cards : 10%

20~30 year age group more sensitive to card design

(Source: *NFO Financial Services*)

⇒ Design is an effective means to attract customers in the 20~30 year age group

DatacardGroup

Design Is Important

- Choice in card design is no longer just something nice to have.
- Choice in card design is becoming an integral part of a successful card program.
- The statistics tell the story. Choice in card design...
 - Lowers customer acquisition costs
 - Improves profitability per account
 - Increases customer loyalty and retention

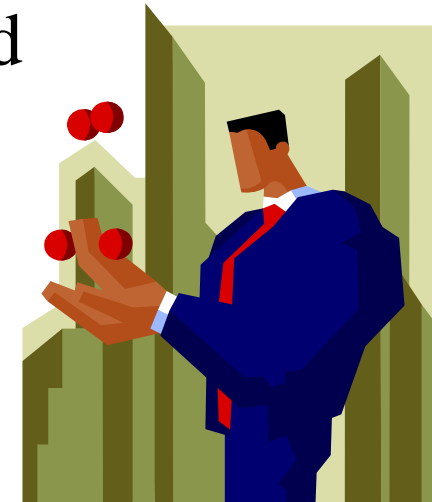

Most powerful in the 20-30 year age group

Financial Market

Benefits

- Credit cards
 - Debit cards
 - Co-branded cards
 - Retail credit cards
- Marketing to one
 - Turnkey solution
 - Small production runs easy & affordable
 - Shortened lead times



Datacard Group

Seeking MC or VISA Approval

- Each association member must submit samples of their financial cards to VISA and/or MasterCard for approval.
- Datacard cannot seek approval directly for their technology; each customer must seek approval for their Artista printer card designs individually.
- Local branded cards do not have restrictions in card designs like MC and VISA.



Process for VISA®-type Card



Step 1: Card ordered from card plant with pre-applied hologram and marks panel.



Step 2: Image and masked area (green) applied by Artista printer. Image not applied to white “knock out” area.



Step 3: Completed Artista printed card



Step 4: CardGard™ applied; card personalized (embossed) by 7000/9000 system.

VISA® Approved Design

Norway

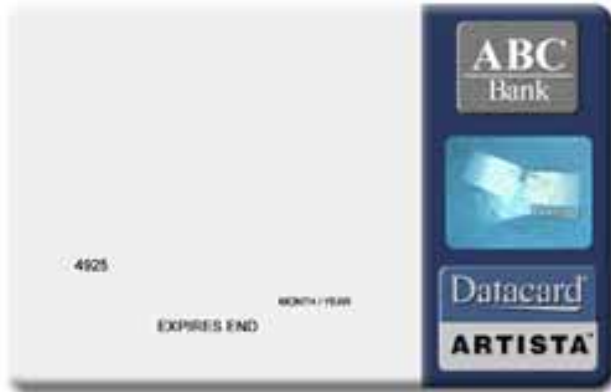

Datacard Group

MasterCard® Approved Design

U.S.A.



Datacard Group

Fastest Growing Market

Retail Market

- Loyalty cards
- Gift cards
- Retail credit cards
- Collector cards

Benefits

- Marketing to one
- Turnkey solution
- Easy to implement
- Shortened lead times



“The stored value/gift card business is an emerging market with potential for **explosive growth.**” *Michael Yerington, Pres. ValueLink® (FDR)*

Datacard Group

Newest Retail Card Trend

Pre-paid Financial Gift Cards



“Business from gift cards is growing at over 15% per year. Gift card revenues are increasing approximately \$5.00 for every \$1.00 revenue decrease for paper gift certificates.”

Vesta TR Corp. web site

Datacard Group

Markets - Telecom

- Corporate phone cards customized with logos, locations, divisions, individuals
- Prepaid phone cards where small volumes are required:
 - Limited edition collector cards
 - Customized for a specific group or company
 - Gift cards personalized to an individual or event

Benefits

- Quantities from 1- many
- Full color customized printing
- Fast fulfillment for time sensitive events



Markets - Telecom

Current situation

High volumes of generic cards are printed without customization

Problem

Generic designs do not provide for customized needs of many businesses including low volume or regional issuance programs

Solution

Artista prints one side of generic cards with custom information, allowing for a wide variety of full color personalization in small batches.



Sample Telecom Issuance

- Large volumes of cards ordered with one pre-printed side and chip or stripe embedded
- Small volumes of blank side printed in color on Artista with advertising or promotion
- Card numbers and scratch-off applied using other Datacard equipment in-house or through a service bureau



Sample Telecom Issuance



Datacard Group

Key Features

- Five print heads
- CMYK printing
- 1,000 cph, 300 dpi
- True edge-to-edge printing
- Error log and job tracking
- Printing on pre-embedded chip cards



Key Features

- Write/Read in-line encoding - tie into 9000
- Cards de-bowed prior to stacking
- LCD operator touch screen
- Partial printing option - control & flex. On how colors printed , i.e., ID photos, logos
- Compatible with CardGard™ for financial applications (added card life 3-5 yrs.)
- 9000/7000 performs look-up on mag stripe for further personalization, topcoat application, and card delivery.

Types of Card Stock

Artista can print on virtually any polished CR-80 card stock.

- Layered or solid core
 - 0.018” to 0.030”/0.46 mm to 0.76 mm

Polished Plastic

- PVC
- Polycarbonate
- ABS
- Polyester
- PETg
- Composite

Artista Printer Data Flow

Server w/Image
Composition Software

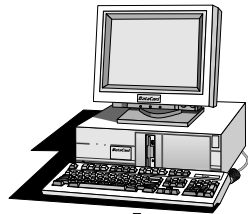

Data
Records

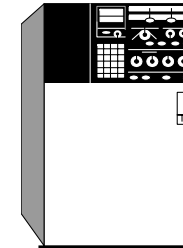

Mainframe

**Combines card
elements RGB TIFF
files created**

Server w/Queue Manager Software

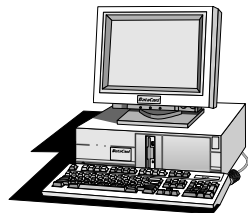

- File queue
- Color separation
- Errors/Audit trail

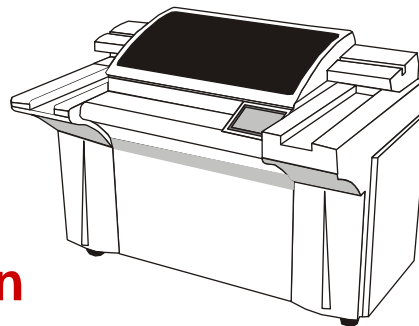

Artista Printer

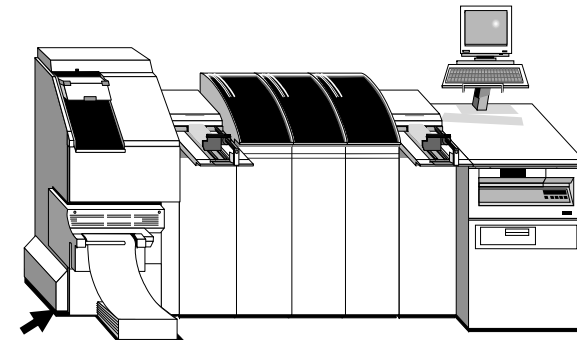

Move to 9000/7000 for
further personalization

Datacard Group



Artista Printer Software

Queue Manager Software (QMS)

- Queues files for printing
- Separates the RGB image data into the proper (3-5) color printing planes
- Monitors printing progress, provides error handling and audit trail

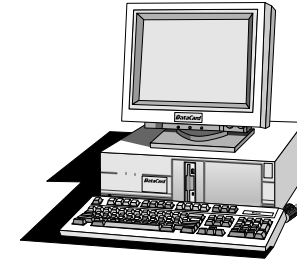

Artista Printer Software - Card Layout

Image Composition Software (ICS)

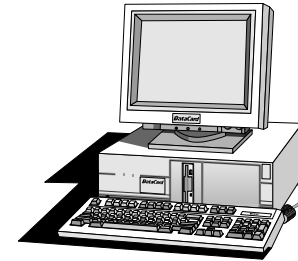

- Card Design
 - Provides means of creating card template that is personalized to individual and based on variable elements (tells the software where to place each element on the card)
- Personalization
 - Initiates parsing of data record into ICS database
 - Pulls out graphics, photo, signature, and mag stripe from 9000 data stream and places in ICS database.

Artista Server Software - Card Layout

- Extracts images, logos, backgrounds, fixed and variable data from ICS database
- Composites up to 255 elements into single RGB TIFF file
- Passes finished records to Artista Queue Manager Server for printing on Artista



Product Support & (AS)

- Full service and training included in price
- Implementation Planning Meeting
 - Evaluation of the cs. site and processes
 - Plan how Artista will be implemented without disrupting their business
- Training
 - Operator/Administrator
 - Graphic Artist

Summary

- ① Customized card designs are popular and profitable.
- ② The Artista turnkey system prints **true edge-to-edge** full card images at 1,000 cph.
- ③ The Artista printer prints fully customized cards to respond to “markets of one” or the demand for customization.
- ④ The Artista printer will make small print runs faster, easier, and more cost efficient.
- ⑤ The Artista printer provides fast turnaround and reduces the need for customized card stock.

